

Product Features

- USB 3.0 and BT-1120 simultaneous output
- 5 megapixel square pixel sensor
- 4 configurable IOs/triggerable
- DirectX, DirectShow & UVC compliant
- Complete SDK available
- Push to set white balance
- Software controllable features and functions via I²C (option)
- Small compact board design (32mm x 32mm) double board
- FPGA produced by Videology - potential for adding unique commands

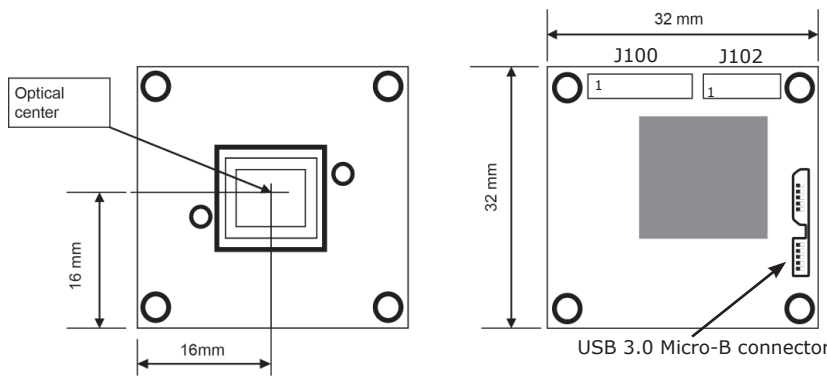

Shown with optional lens



J102 Connector (Molex-501920-3001)

01	GND	11	Y4	21	TBD
02	GND	12	IO-TBD	22	GND
03	Y0	13	Y5	23	LV
04	IO-TBD	14	IO-TBD	24	FV
05	Y1	15	Y6	25	Y8
06	IO-TBD	16	IO-TBD	26	IO-TBD
07	Y2	17	Y7	27	I2C-DAT
08	IO-TBD	18	IO-TBD	28	I2C-SCL
09	Y3	19	CLOCK	29	Y9
10	IO-TBD	20	IO-TBD	30	+5V

J100 Connector (JST-SM10B-SRSS)

01	GPIO0 (SNAP USB3)	05	GPIO4	09	GND
02	GPIO1	06	GPIO5	10	Vin (4.5-5)
03	GPIO2	07	GPIO6		
04	GPIO3	08	GPIO7		

J100 Connector (USB 3.0 Micro B)

Technical Specifications

Electrical	24C5.0XUSB3
Output Format	USB 3.0 / BT-1120
Supported Resolution	640 x 480 VGA @120fps 720p @ 60fps 1080p @ 30fps 2592 x 1944 @ 14.5fps
Image Sensor	1/2.5" CMOS
Scan Mode	Progressive scan
Active Pixels	2.2µm x 2.2µm
Sensitivity	1.0 lux
Signal to Noise Ratio	>38dB
Dynamic Range	70.1dB
Gain Control	Automatic (default) / manual
Shutter	Rolling shutter (automatic or fixed)
Control Communication	Camera control via USB, I ² C option
Backlight Compensation	Selectable (Default OFF)
White Balance	Auto / manual
Mirror/Flip Mode	Selectable via software (H & V direction)
Supply Voltage	5V bus powered or external 5V input +/- 10%
Power Consumption	1.8W

Environmental

Operating Temperature	-15°C ~ 60°C (5°F ~ 140°F)
Operating Humidity	20 up to 93%RH
Storage Temperature	-40°C ~ 80°C (-40°F ~ 176°F)
Storage Humidity	Up to 94%RH
Lifetime MTBF	> 150,000 hrs
Packaging	ESD safe package

Mechanical

Dimensions W x H x D	32mm x 32mm x 20mm (without lens mount) (1.26" x 1.26" x 0.79")		
Weight	40g (1.4oz)		
Lens Mounts	Replace "X" in model number with desired lens:		
Example: 24B5.0XUSB3.0 will change to 24B5.05USB3.0 to select an M-12 board mount.	2 = Metal M-12 Pinhole	5 = Metal M-12 Board	8 = Metal CS Board

Software

Viewer Software SFT-15010	<ul style="list-style-type: none"> • USB 3.0 interface (USB 3.0 port required) • UVC (USB video class) compliant • DirectX/DirectShow compliant • Compatible with Windows 7, 8 and 10
SDK (Optional) (For UVC extensions)	Please talk to a Videology Sales Rep. for details.

I²C Communication Kit (Optional)

60C5-U	I ² C board, program cable, USB cable, camera control software
--------	---

Accessories

Optional	60C1183	6ft. USB 3.0 type A cable to USB micro B (Blue)
----------	---------	---

Optional Models

24B5.0XUSB3	Monochrome 5MP USB3 camera
-------------	----------------------------