

LT8711EH-C --- Product Brief

Type-C/DP1.2 to HDMI2.0 Converter

Features

● USB Type-C

- Compliant with VESA DisplayPort Alt Mode on USB Type-C Standard V1.0
- Compliant with USB Power Delivery Specification R2.0, V1.0
- Compatible with USB Type-C Cable and Connector Specification R1.2
- Built-in dual CC controllers for charger and normal communication
- Compliant with HDMI 1.4b Alt Mode on USB Type-C Specification V1.0

● DP1.2 Receiver

- Compliant with VESA DP1.2
- Support 1.62/2.7/5.4Gbps
- Support 1/2/4 lanes
- Support SSC
- 1Mbps AUX channel
- Compliant with HDCP1.3
- Adaptive receiver equalization for PCB, cable and connector losses
- Support lane swap(arbitrarily) and polarity inversion(independent)
- Receiver PHY is HDMI signal compatible

● HDMI2.0 Transmitter

- Compliant with HDMI2.0, HDMI1.4 and DVI1.0
- Compliant with HDCP2.2 and HDCP1.4
- Data rate up to 6Gbps
- Support UHD 4k@60Hz(RGB and YCbCr 4:4:4)
- Support TMDS scrambling for EMI/RFI reduction
- Support SCDC(Status and Control Data Channel)
- AC-couple capable
- Support channel swap(arbitrarily) and polarity inversion(independent)

- Programmable transmitter swing and pre-emphasis
- Downstream receiver sensing
- 5V tolerance DDC/HPD I/Os

● Miscellaneous

- DP receiver to HDMI transmitter bypass to support HDMI Alt Mode
- Internal or external oscillator
- Integrated microprocessor
- Embedded SPI flash for firmware and HDCP keys
- GPIOs for VBUS/VCONN/AUX and other system controls
- Integrated 100/400kHz I2C slave
- Firmware update through SPI, AUX or I2C interface
- Low power consumption
- Power supply: 3.3V for I/O and 1.2V for core
- ESD 4kV HBM
- Temperature Range: -40°C ~ +85°C
- 64-pin QFN 7.5*7.5 package

Description

The LT8711EH-C is a high performance Type-C/DP1.2 to HDMI2.0 converter, designed to connect a USB Type-C source or a DP1.2 source to an HDMI2.0 sink.

The LT8711EH-C integrates a DP1.2 compliant receiver, and an HDMI2.0 compliant transmitter. Also, two CC controllers are included for CC communication to implement DP Alt Mode and power delivery function, one for upstream Type-C port and another for downstream port.

The device is capable of automatic operation which is enabled by an integrated microprocessor that uses an embedded SPI flash for firmware storage. System control is also available through the use of a dedicated configuration I2C slave interface.

Application

- Docking Station
- Dongle

Block Diagram

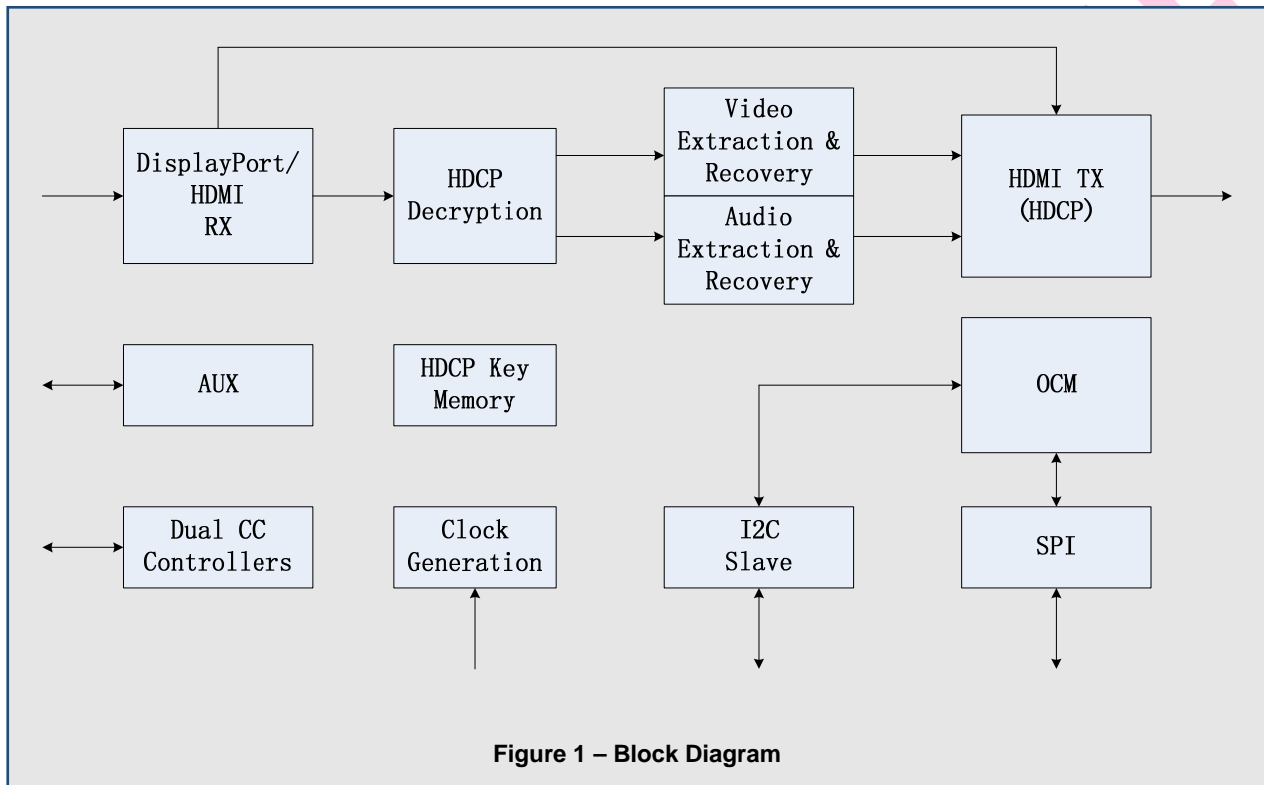

Ordering Information

Part Number	Operating Temperature Range	Package	Packing Method
LT8711EH-C	-40°C to +85°C	QFN64 7.5*7.5	Tray
LT8711EH-CI	-40°C to +85°C	QFN64 7.5*7.5	Tray

Lontium Semiconductor Proprietary & Confidential

This document and the information it contains belong to Lontium Semiconductor. Any review, use, dissemination, distribution or copying of this document or its information outside the scope of a signed agreement with Lontium is strictly prohibited.

LONTIUM DISCLAIMS ALL WARRANTIES, EXPRESSED OR IMPLIED, INCLUDING THOSE OF NONINFRINGEMENT, MERCHANTABILITY, TITLE AND FITNESS FOR A PARTICULAR PURPOSE. CUSTOMERS EXPRESSLY ASSUME THEIR OWN RISK IN RELYING ON THIS DOCUMENT. LONTIUM PRODUCTS ARE NOT DESIGNED OR INTENDED FOR USE IN LIFE SUPPORT APPLIANCES, DEVICES OR SYSTEMS WHERE A MALFUNCTION OF A LONTIUM DEVICE COULD RESULT IN A PERSONAL INJURY OR LOSS OF LIFE.

Lontium assumes no responsibility for any errors in this document, and makes no commitment to update the information contained herein. Lontium reserves the right to change or discontinue this document and the products it describes at any time, without notice. Other than as set forth in a separate, signed, written agreement, Lontium grants the user of this document no right, title or interest in the document, the information it contains or the intellectual property it embodies.

Trademarks

Lontium™ and ClearedEdge™ is a registered trademark of Lontium Semiconductor. All Other brand names, product names, trademarks, and registered trademarks contained herein are the property of their respective owners.

Visit our corporate web page at: www.lontiumsemi.com

Technical support: support@lontium.com

Sales: sales@lontium.com